

# Electric Fuel Pump

## FPM

**D SERIES**

FPM-12, FPM-12/HF, FPM-24, FPM-115, FPM-220

**Congratulations on purchase of this World Class Electric Fuel Pump!**

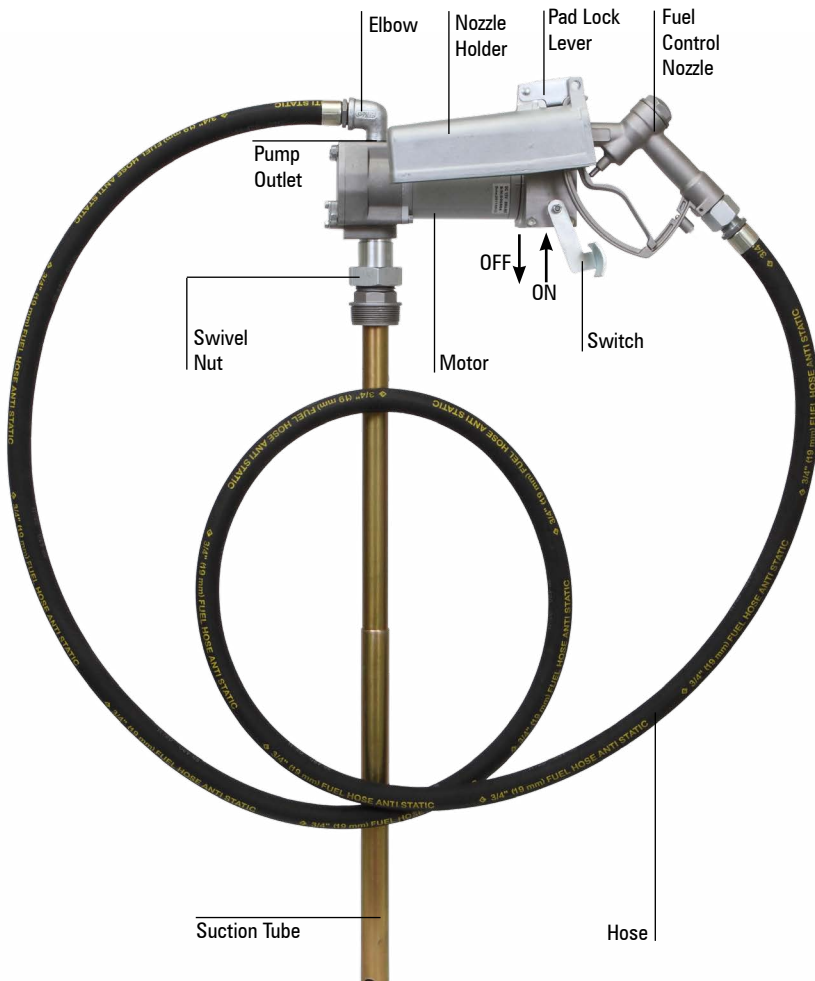

This is an Electric Fuel Pump. Pump uses 2 Sintered Powder Metal gears for suction & is designed for use with Gasoline, Diesel, E15 Fuel, Kerosene, Bio Diesel (B20) etc. In ideal laboratory conditions, pump dispenses up to 15 GPM (57 LPM) at the pump outlet. In case of High Flow Model FPM/12/HF, discharge is 20 GPM (75 LPM). The actual discharge varies depending on fuel being used, temperature, Hose Length, power supply etc.

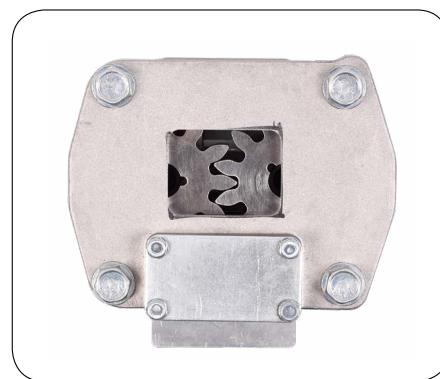

Inside of Pump

Pump Comes in 4 Power Ratings

- 12V DC
- 24V DC
- 115V AC, 60 Hz.
- 220V AC , 50/ 60 Hz

Rating is marked on the pump motor.

## PUMP CONSTITUENTS

1. Pump & Motor Assembly
2. Nozzle Holder
3. Elbow
4. Suction Tube (2 parts)
5. Bung Nut
6. Hose Assembly (12' Long x 3/4" ID Anti Static Hose)
7. Fuel Control Nozzle
8. Gland Nut
9. Power Cord complete with Fuse & Clamps\*
10. PTFE Tape

\*Only included on DC pumps. AC pumps are supplied without power cord

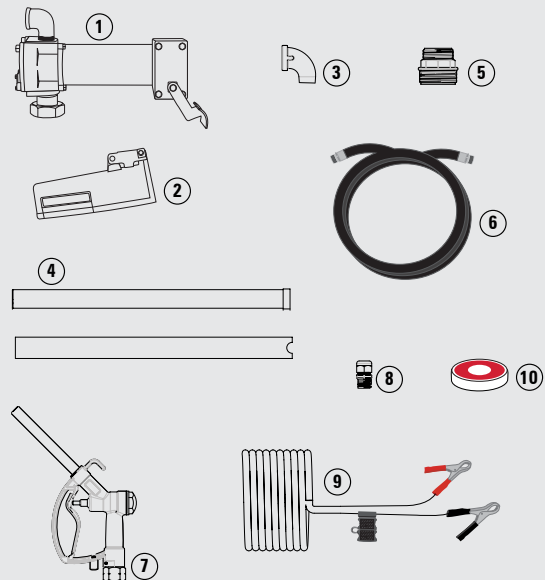

## ELECTRICAL INSTALLATION - 12V & 24V DC Pumps

1. Ensure pump switch is OFF

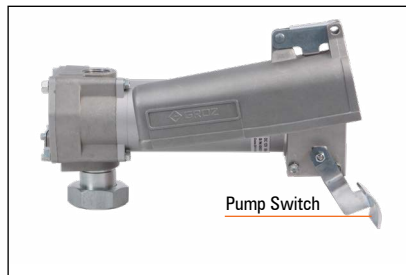

2. Electrical cover is located on the opposite side of the ON/OFF Switch. Take a wrench & open the 4 bolts to open the Electrical Cover

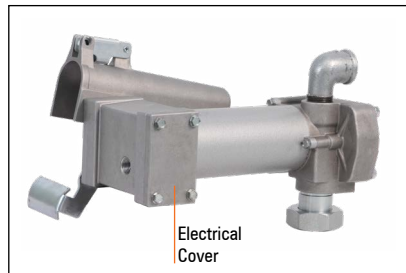

3. Take out the Power Cord supplied with the pump. It may be cut to a shorter length as per requirement

4. Strip 3" (75 mm) of outside black coloured insulation from power cord from the end opposite to the fuse

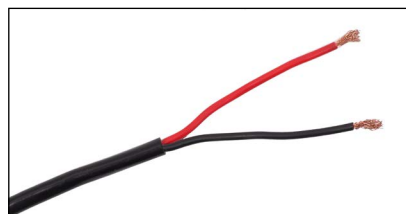

5. You would see Black & Red Wires after the black insulation is removed. Strip 3/8" (10 mm) from the Black & Red wires

6. Take out the Gland Nut from the package & open the 2 parts of the Gland Nut

7. Slide the Nut portion of the Gland Nut over the end of power cord on the end just stripped. Now Slide the other part of the Gland Nut as well ensuring that the male threaded portion of the gland nut faces the stripped end of the power cord. Connect the 2 halves of the gland without tightening it much

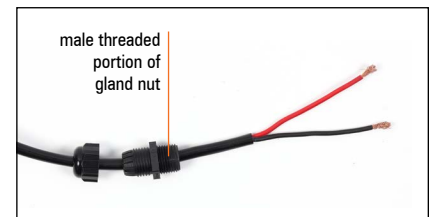

8. Insert power cable from the threaded opening on the Electrical Housing

9. Connect wires from power cord to wires from the motor using Wire Nuts. Connect Red to Red & Black to Black



10. Screw Gland Nut into the Electrical Housing

11. Position power cord & tighten the Nut portion of the Gland Nut ensuring that power cords connection with the motor is not under any strain

12. Re-install Electrical Cover on the pump & tighten using the 4 bolts

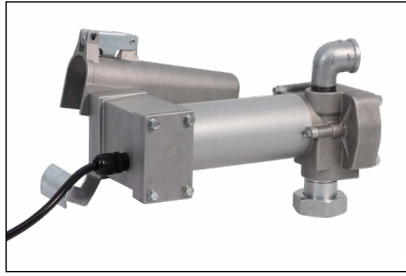

14. Attach battery clamps with red sleeve to red wire & black sleeve to black wire. Wire must be crimped to the battery clamp firmly to get a good electrical connection

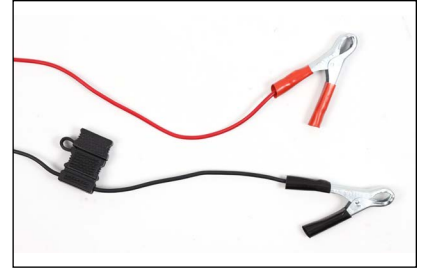

13. Remove 1/2" ( 13 mm) of insulation from wires on the fuse holder end of the power cord

## ELECTRICAL INSTALLATION - 115V AC & 220V AC Pumps

On 115V AC & 220V AC pumps, electrical connections must be made by a licensed electrician.

Only rigid conduit with threaded connections should be used.

Conduit opening in pump must be sealed with waterproof, fuel-resistant sealant. Failure to comply with this warning could result in injury from Electrical shock

1. Ensure pump switch is OFF
2. Electrical cover is located on the opposite side of the ON/OFF Switch. Take a wrench & open the 4 bolts to open the Electrical Cover
3. AC Power Cord is not supplied with the pump & you must purchase one separately
4. Strip 3" (75 mm) of outside insulation from power cord
5. You would see Black, White & Green Wires after the insulation is removed. Strip 3/8" (10 mm) from all 3 wires

6. Take out the Gland Nut from the package & open the 2 parts of the Gland Nut
7. Slide the Nut portion of the Gland Nut over the end of power cord on the end just stripped. Now Slide the other part of the Gland Nut as well ensuring that the male threaded portion of the gland nut faces the stripped end of the power cord. Connect the 2 halves of the gland without tightening it much
8. Insert power cord from the threaded opening on the Electrical Housing
9. Connect wires from power cord to wires from the motor using Wire Nuts. Connect Green to Green , White to White & Black to Black
10. Screw Gland Nut into the Electrical Housing
11. Position power cord & tighten the Nut portion of the Gland Nut ensuring that power cords connection with the motor is not under any strain
12. Re-install Electrical Cover on the pump & tighten using the 4 bolts

## ASSEMBLY & INSTALLATION

**Ensure tank / drum being used is clean & free of welding slag. Ensure the tank is vented to allow air into the tank as fuel is being pumped out. Failure to provide a vent will cause priming problems**

1. Wrap around PTFE tape on the following male threaded joints. This will ensure a leak-proof connection
  - Male Threads on the Elbow
  - Male Threads on the Fitting ends of the Hose
  - Male threads between the 2 Suction Tube parts
  - Male threads on the Suction tube end that fits into the pump inlet

2. Assemble the Nozzle Holder with the pump. In order to do so, open the 2 bolts on top of the On / Off Switch. Remove the bolts & re-attach along with the nozzle holder



- Now Fasten the Elbow into the pump outlet & hand tighten. Once you can no longer hand tighten, take a wrench & tighten the elbow by about  $\frac{1}{2}$  a turn.

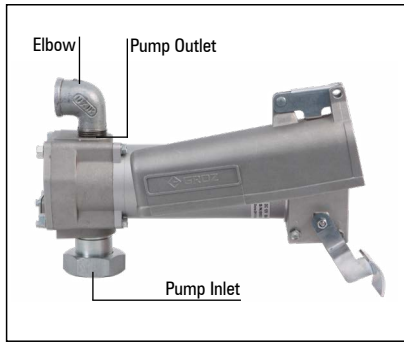

- Take the Bung Nut & fasten it onto the 2" opening on the Drum/Tank. Bung Nut has a large 2" thread & a small 1-1/2" thread. 2" thread goes into the drum/tank, whereas the 1-1/2" thread is for connecting bung to the pump



- In case the Bung Nut does not fit onto your drum/tank, use a Drum Bung Converter. Note that bung supplied with the pump has 2" Pipe threads

- Connect the two halves of the Suction Tube. Suction tube is designed for use with tanks / drums which are 36" (914 mm) deep & has a total connected length of 34" (865 mm). In case you are installing the pump on a tank that is deeper, you would have to get a standard 1" dia. tube with 1" NPT threads on one end. Suction tubes longer than 5' (1.52 m) require a foot valve (not provided) at the bottom of the tube to prevent loss of prime. For shallower drums, cut the suction tube to the desired length. Ensure that there is about 2" (50 mm) gap between the bottom of the tank/drum & inlet of the suction tube allowing for easy entry of fuel into the tube. Now connect the Suction Tube to the pump inlet. Hand tighten



- Lift the Pump from the motor. Be careful as the assembly is heavy. Insert suction tube into the drum through the 2" opening on the drum. Use the Swivel Nut mounted at the pump inlet to fasten onto the Bung Nut. Hand tighten



- Take the Fuel being dispensed & pour it into the pump outlet, until completely filled. This will ensure that the gear chamber stays lubricated & makes it easier for the pump to prime

- Take the Hose Assembly & connect the threaded end onto the Elbow at the pump outlet. Hose has a hex nut at the threaded end which can be tightened to the elbow using a wrench



- Connect the other end of the Hose to the Fuel Control Nozzle

- Connect Power cord to source of power & switch it ON

- The pump is now ready for use



## PRIMING

All pump models using the supplied 34" (865mm) suction tube should prime within 10 seconds after pump is turned on. Pumps installed at a height upto 5' (1.52 m) may have difficulty in priming. Follow the procedure below to initiate priming. Pumps installed at a suction height above 5' (1.52m) may have difficulty in holding prime. It is recommended that a foot valve with ball check (not supplied with the pump) be added to the bottom of the suction tube to maintain prime

1. Remove the Elbow from the pump outlet
2. Pour fuel being pumped into the pump outlet until completely filled
3. Re-assemble the Elbow back into the pump outlet & turn the pump on. Pump should get primed in less than 10 seconds
4. If pump still does not gain prime, check for any major leaks in the system. If no leaks are found, then the pump is mechanically defective & should be reported back to your Distributor

## PUMP OPERATION

1. Remove Nozzle from the Nozzle Holder. The On\ Off switch can be Switched ON only once the nozzle is removed from the nozzle holder



2. Nozzle should be facing the container into which Fuel is to be dispensed

3. Pump On/Off Switch Lever is located under the nozzle holder. Move switch lever ON & simultaneously open the Nozzle



Pump in ON Position

4. In less than 10 seconds, the pump will be primed & fuel will start dispensing from the Nozzle
5. Dispensing Action can be stopped by closing the Nozzle, with the pump still ON. This however must not be done for more than 5 minutes. **DO NOT operate the pump for more than 30 minutes continuously in 1 hour**
6. It is best practice to Switch Lever in the OFF position to stop dispensing
7. **The pump must never be run dry (no media in the drum) as that can possibly cause irreparable damage to the motor**
8. Once Dispensing is completed, switch off the Lever & disconnect power supply to the pump
9. Store the Nozzle Back into the Nozzle Holder

### WARNING

Do not use curb pump auto nozzle with this pump. Contact your distributor for auto nozzles for use with electric fuel pumps

## MAINTENANCE

1. Clean Inlet Strainer after every 50 hours of operation
2. Inlet strainer is easily accessible without having to disassemble the pump. Strainer is installed just above the pump inlet & can be accessed by removing the 4 bolts on the side of the pump holding the Strainer cover
3. Remove & clean strainer
4. If strainer is excessively dirty, clean tank to protect pump and the equipment being fuelled
5. After cleaning strainer, replace strainer & cover. Make sure cover seal is in place



# EXPLODED VIEW FOR FPM-12, FPM-12/HF, FPM-24, FPM-115, FPM-220

## PUMP ASSEMBLY

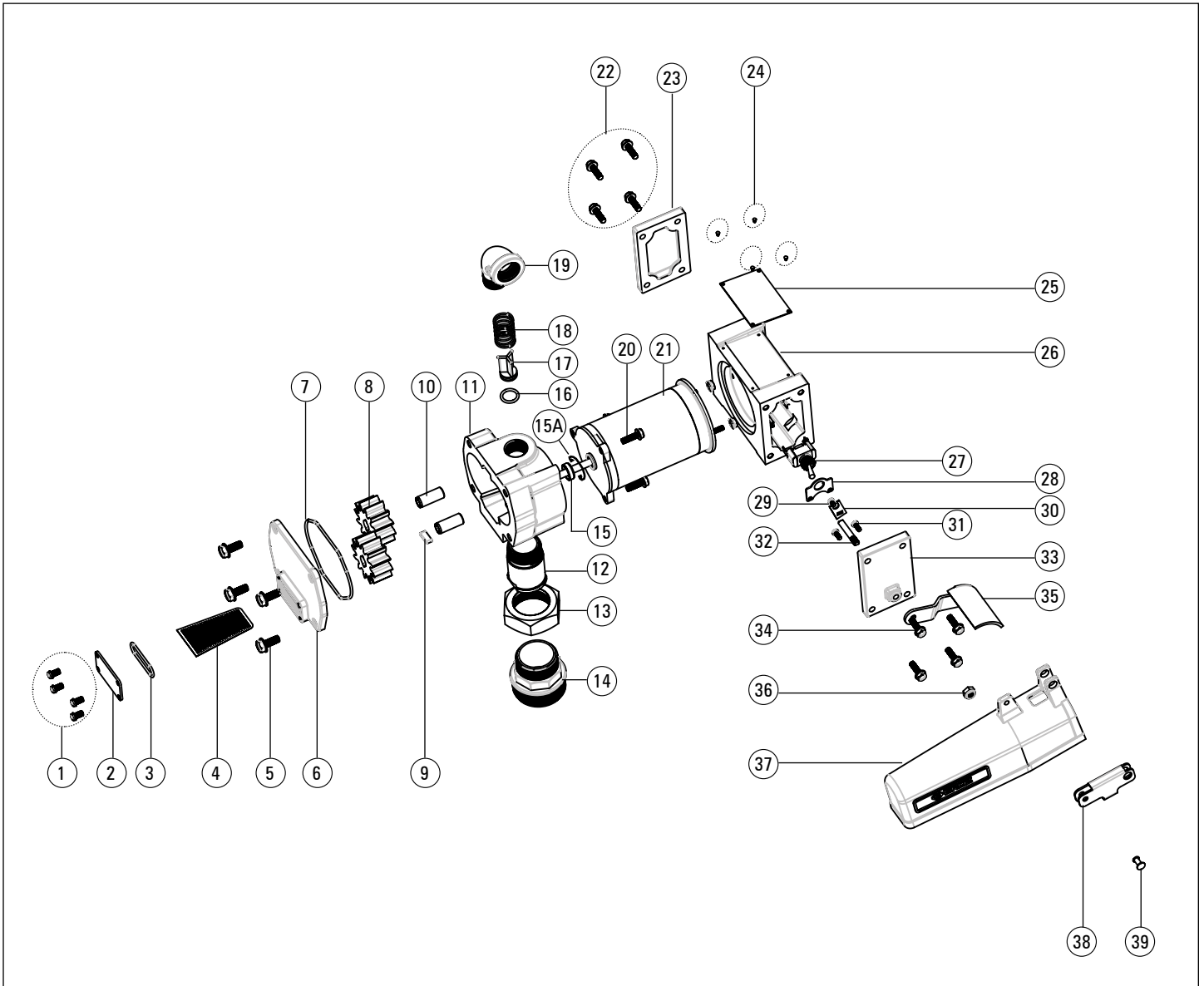

## HOSE, SUCTION TUBE, POWER CABLE & FUEL CONTROL NOZZLE ASSEMBLY

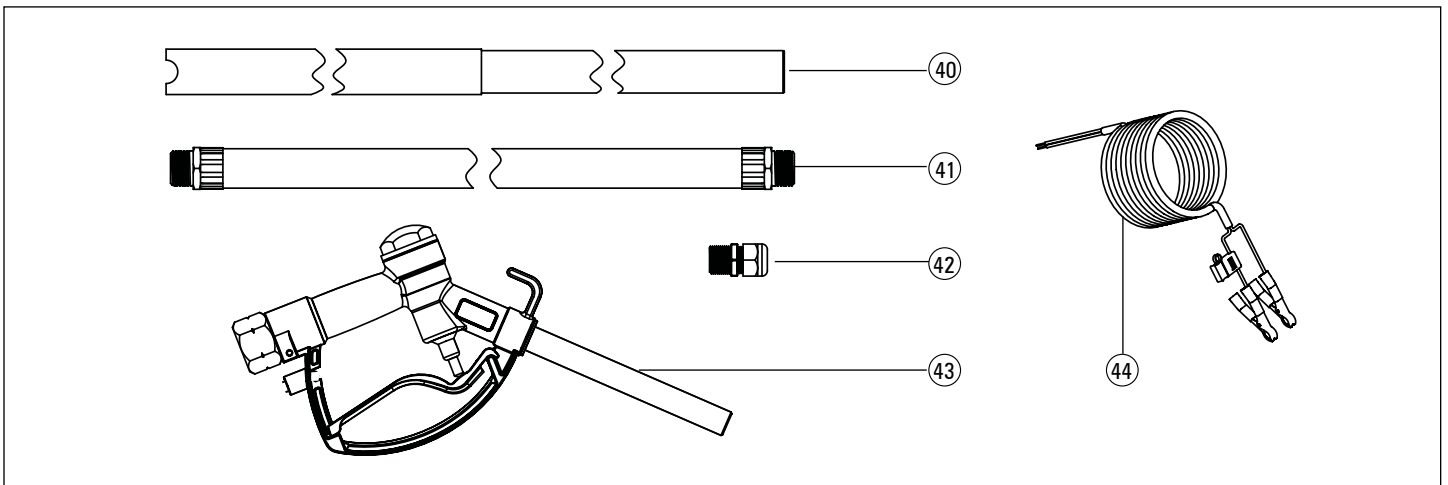

# PARTS LIST FOR FPM-12, FPM-12/HF, FPM-24, FPM-115, FPM-220

## PUMP ASSEMBLY

REFERENCE NUMBER	DESCRIPTION	QUANTITY
1	Thread Forming Bolt M4	4
2	Cover (Strainer)	1
3	O-Ring	1
4	Strainer	1
5	Thread Forming Bolt M8	4
6	Housing Cover	1
7	O-Ring	1
8	Gear	2
9	Key Gear	1
10	Shaft (Gear)	2
11	Housing (Machined)	1
12	Fitting (Bung)	1
13	Swivel Nut	1
14	Bung Adaptor	1
15	Seal (Metal Inserted)	1
15A	Circlip	1
16	O-Ring (Viton)	1
17	Bypass Valve	1
18	Spring (Bypass Valve)	1
19	Elbow	1
20	Thread Forming Bolt M6	9
21A	<b>Motor, 12V DC</b>	1
21B	<b>Motor, 12V DC HF</b>	1
21C	<b>Motor, 24V DC</b>	1
21D	<b>Motor, 115V AC, 60 HZ</b>	1
21E	<b>Motor, 220V AC, 50 HZ</b>	1
22	Thread Forming Bolt M4	4
23	Electrical Cover (M/C)	1
24	Drive Screw U Type	4
25	Label	1
26	Electrical Housing (M/C)	1
27	On Off Toggle Switch (SPST) with Spade Terminal (15 AMPS, 250V)	1
28	Bracket (Switch)	1
29	Screw (CAM)	2
30	Cam (Switch)	1
31	Thread Forming Bolt Screw M4	2
32	Shaft (Lever)	1
33	Switch Cover (M/C)	1
34	Thread Forming Bolt M6	4
35	Lever	1
36	Nylock Nut	1
37	Cover Nozzle	1
38	Lock	1
39	Rivet	1
<b>HOSE, SUCTION TUBE, POWER CABLE &amp; FUEL CONTROL NOZZLE ASSEMBLY</b>		
40	Suction Tube	1
41	Hose Assembly	1
42	Plastic Gland (Wiring)	1
43	Fuel Control Nozzle	1
44	Power Cable Assembly (Only for DC Pumps)	1

## PUMP SPECIFICATION

	<b>FPM-12</b>	<b>FPM-12/HF</b>	<b>FPM-24</b>	<b>FPM-115</b>	<b>FPM-220</b>
<b>Description</b>	Heavy Duty 12V DC	High Flow 12V DC	Heavy Duty 24V DC	Heavy Duty 115V AC	Heavy Duty 220V AC
<b>Flow Rate*</b>	Up to 15 GPM (57 LPM)	Up to 20 GPM (76 LPM)	Up to 15 GPM (57 LPM)	Up to 13 GPM (49 LPM)	Up to 13 GPM (49 LPM)
<b>Explosion Proof Motor</b>	1/7 HP 12V DC	1/7 HP 12V DC	1/7 HP 24V DC	1/8 HP 115V AC, 60 Hz.	1/8 HP 220V AC, 50/60 Hz.
<b>Amp draw from Battery</b>	12 Amp	15 amp	6 amp	1.7 Amp	1 Amp
<b>Internal Bypass Valve</b>	Yes	Yes	Yes	Yes	Yes
<b>Suction Pipe</b>	2 pc threaded	2 pc threaded	2 pc threaded	2 pc threaded	2 pc threaded
<b>Hose</b>	3/4" x 12' Anti Static Hose	1" x 12' Anti Static Hose	3/4" x 12' Anti Static Hose	3/4" x 12' Anti Static Hose	3/4" x 12' Anti Static Hose
<b>Tank Adaptor</b>	2" Threaded	2" Threaded	2" Threaded	2" Threaded	2" Threaded
<b>Inlet</b>	1" NPT	1" NPT	1" NPT	1" NPT	1" NPT
<b>Outlet</b>	3/4" NPT	1" NPT	3/4" NPT	3/4" NPT	3/4" NPT
<b>Dispensing Nozzle</b>	3/4" Manual with Swivel	1" Manual with Swivel	3/4" Manual with Swivel	3/4" Manual with Swivel	3/4" Manual with Swivel
<b>Battery Cable (2 wire)</b>	15'	15'	15'	NA	NA

\* measured in lab conditions at pump outlet using Diesel with vehicle engine switched on

### WETTED COMPONENTS

Aluminium, Steel, Cast Iron, Nylon, NBR, Zinc, Viton, Polypropylene

### RECOMMENDED USE

Gasoline, Diesel, E15 Fuel, Kerosene, Bio Diesel (B20)

# TROUBLESHOOTING

PROBLEM	CAUSE	SOLUTION
<b>Motor runs but pump will not prime</b>	Motor rotation wrong. (12 VDC and 24 VDC units only)	Check wiring instructions for possible problems
	Missing relief valve o-ring seal (16)	Remove gear cover (6), inspect seal, replace if missing or damaged
	Sheared drive key (9)	Remove cover (6) and inspect key, replace if worn or sheared
	Dirt under by-pass valve (17) or seal (16)	Remove cover (6) and inspect, clean or replace if damaged
	Strainer seal (3) leaking	Inspect and replace if damaged
	Suction height too high to prime	See Priming Pump, page 5
	Worn or damaged gears (8)	Remove cover (6) and inspect gears. Replace if worn or damaged
	Fuel level low	Refill tank
	Cover seal (7) damaged	Replace if worn or damaged
	Inlet strainer (4) clogged	Remove and clean or replace
	Air leak in suction tube (40)	Inspect all joints in suction tube. Make sure all joints in suction tube are sealed and that there are no cracks from over-tightening
	Air lock in system	This may occur if filter or meter or automatic shut-off nozzle is used. If this occurs, fill pump and meter with fuel through top of pump
	Motor does not run at proper speed	Check electric connections. Check supply voltage for proper voltage level
	Curb Pump Auto Nozzle used	Change to Auto Nozzle for use with Electric Fuel Pumps
<b>Unit pumps but output flow is low</b>	Clogged inlet strainer (4)	Clean or replace
	Air leak in suction tube (40)	Check to make sure all joints in suction tube are sealed and that there are no cracks
	Suction tube (40) too close to tank bottom	Suction tube must have a 2 in. (50 mm) minimum clearance
	Tank empty	Refill tank
	Tank not vented	Tank must be vented to atmosphere
	Worn or damaged gears (8)	Remove cover (6) and inspect gears. Replace if worn or damaged
	Damaged motor (21)	Replace motor
	Clogged suction tube (40), hose (41) or nozzle (43)	Inspect and clean
<b>Motor stalls when nozzle is closed</b>	Curb Pump Auto Nozzle used	Change to Auto Nozzle for use with Electric Fuel Pumps
	Bypass relief valve (17) stuck	Inspect relief valve, making sure poppet is free. Replace if damaged
	Low supply voltage	Check supply voltage
	Gears (8) damaged and binding	Inspect gears. Gears should turn freely. Replace if damaged
<b>Fuel leaking in motor mount</b>	Faulty motor (21)	Replace motor
	Faulty or damaged motor shaft seal (15)	Replace shaft seal
	Operating pump extended time with nozzle closed	Do not exceed 5 minutes of operation with nozzle closed
<b>Motor overheating</b>	Motor shaft worn	Replace motor if shaft has worn in seal area
	Gears (8) binding	Check to make sure gears turn freely on shaft
	Operating pump extended time with nozzle closed	Do not exceed 5 minutes of operation with nozzle closed
	Clogged inlet strainer (4)	Clean or replace, see Maintenance, page 5
	Clogged suction tube (40), hose (41) or nozzle (43)	Inspect and clean if required
<b>Switch will not turn pump on</b>	Operating pump more than 30 minutes continuous duty	Limit operation to 30 minutes per hour
	Blown fuse	Replace fuse. 30 amp automotive fuse
	Electrical problem	Check that supply voltage is proper and getting to pump
	Defective switch (27)	Check and replace if defective
	Mechanical problem	Check switch actuator cam. Cam should be actuating the switch
	Damaged or defective motor (21)	Check motor, replace if damaged or defective

# REPLACEMENT & SERVICE PARTS PROGRAM FOR ELECTRIC FUEL PUMPS

---

## REPLACEMENT PARTS PROGRAM

REFERENCE # FROM OIPM	GROZ PART #	DESCRIPTION
21A	MOT/FPM/12	Motor, 12V DC
21B	MOT/FPM/12/HF	Motor, 12V DC HF
21C	MOT/FPM/24	Motor, 24V DC
21D	MOT/FPM/115	Motor, 115V AC, 60 Hz
21E	MOT/FPM/220	Motor, 220V AC, 60 Hz
14	ADP/BNG/FPM/12	Bung Adaptor
40	FPM/2R/N	Suction Tube
41A	SA/HOS/FPM/12	Hose Assembly
41B	SA/HOS/FPM/12/HF	Hose Assembly, HF
42A	SA/FCN/S/3-4/FPM/N	Fuel Control Nozzle
42B	SA/FCN/S/0-1/FPM/N	Fuel Control Nozzle, HF

**SERVICE PARTS PROGRAM**

<b>KIT PART #</b>	<b>KIT DESCRIPTION</b>	<b>CONSTITUENT PART #</b>	<b>CONSTITUENT DESCRIPTION</b>	<b>CONSTITUENT REFERENCE FROM OIPM</b>	<b>QTY. PER KIT</b>	<b>SUPPLY CONDITION</b>
FPM/KIT/SK	Seal Kit	ORG/BS154	O Ring	7	1	SET
		ORG/V/BS809	O Ring (Viton)	16	1	
		ORG/BS126	O Ring	3	1	
		SEL/FPM/12	Seal (Metal Inserted)	15	1	
		CCL/FPM	Circlip	15A	1	
FPM/KIT/GK	Gear Kit	GEAR/FPM/12	Gear	8	2	SET
		KEY/GEAR/FPM/12	Key (Gear)	9	1	
FPM/KIT/SA	Switch Assembly Kit	SWH/FPM	On Off Toggle Switch	27	1	ASSEMBLED
		BKT/SWH/FPM/12	Bracket (Switch)	28	1	
		SCR/CAM/FPM/12	Screw (CAM)	29	1	
		CAM/SWH/FPM/12	Cam (Switch)	30	1	
		TFS/M4/FPM/12	Thread Forming Bolt Screw M4	31	2	
		SFT/LVR/FPM/12	Shaft (Lever)	32	1	
		CVR/SWH/FPM/12	Switch Cover (M/C)	33	1	SET
		LVR/FPM/12	Lever	35	1	
		NN/M6/RP-G	Nylock Nut	36	1	ASSEMBLED
		CVR/NZL/FPM/12	Cover (Nozzle)	37	1	
		LOC/FPM/12	Lock	38	1	
		RVT/FPM/12	Rivet	39	1	
FPM/KIT/PC	Power Cable Assembly Kit	SA/PCLE/FPM/12/HF	Power Cable	43	1	ASSEMBLED



**Groz Engineering Tools (P) Ltd.  
Groz Net Industries**

Village Kherki Daula, National Highway-8  
Gurgaon-122001, Haryana, INDIA  
TEL +91.124.282.7700 / 221.4050  
FAX +91.124.2827986 / 221.4224  
FAX (USA) +1.509.271.7848  
FAX (UK) +44.870.121.1854

E-MAIL [info@groz-tools.com](mailto:info@groz-tools.com)  
URL [www.groz-tools.com](http://www.groz-tools.com)

The Groz name, Groz logo and the  mark are  
trademarks of Groz Engineering Tools (P) Ltd. India